



90t



48m



65.7m

ZOOMLION

TECHNICAL SPECIFICATIONS

ZRT900V5-1

ROUGH TERRAIN CRANE

Edition 1 March 2024

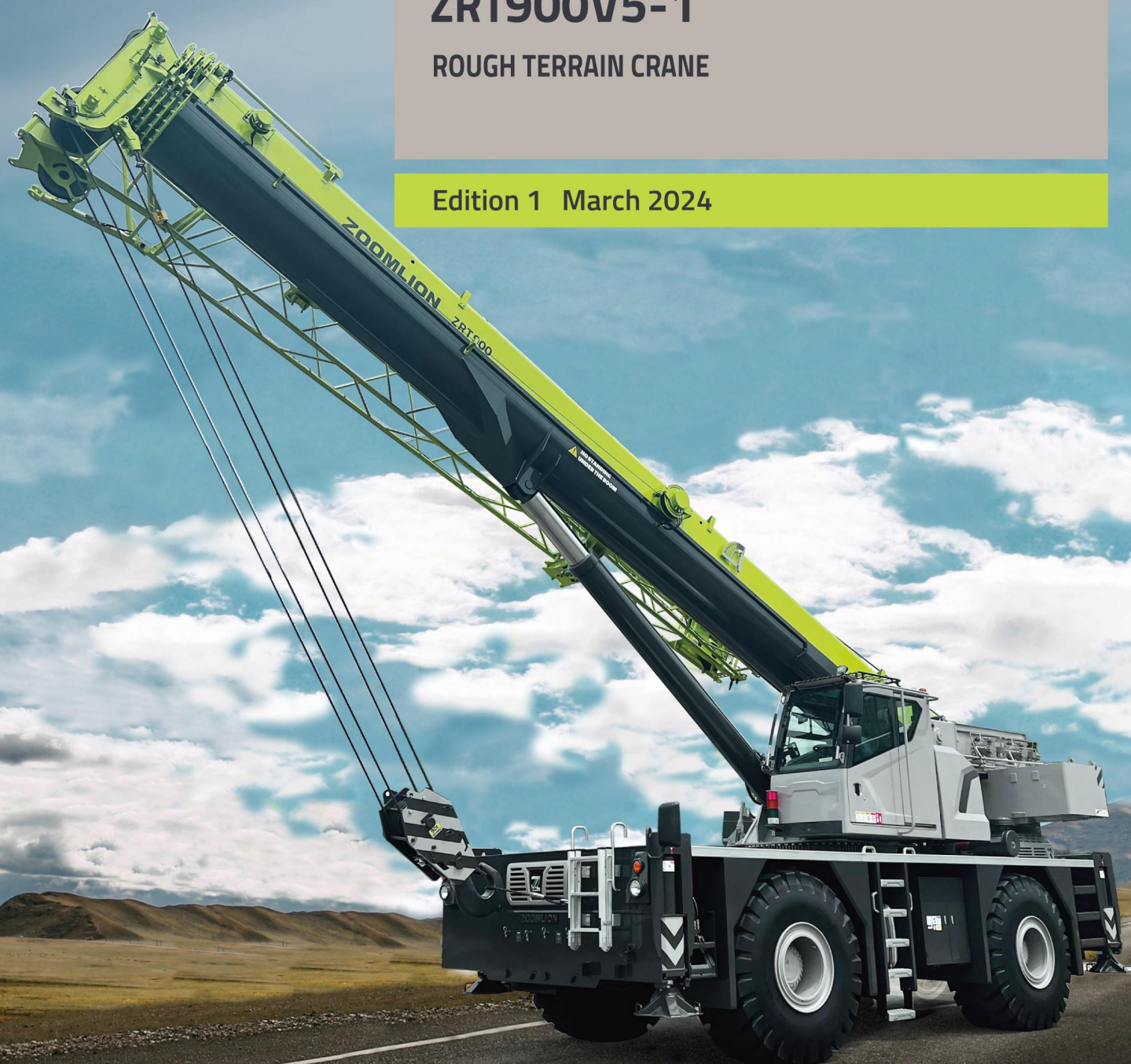

ZOOMLION

PROD
4.0

CONTENTS

01	Overall Dimensions	3
02	ZRT900V5-1 Product Introduction	4-5
03	Main Technical Data	6-7
04	Configuration	8-10
05	Transport	12
06	Combination of Jib Sections	13-15
07	Lifting Height Curve + Lifting Capacity Chart	16-22

ZRT900V5-1 Product Introduction





48m



9.5m-16m



194kw



8.8t

Main Technical Data

Type	Item	Unit	Value
Working performance	Max. rated lifting capacity × working radius	kg.m	90000×2.5
	Max. load moment of the basic boom	kN.m	2950
	Max. load moment of the boom (fully extended)	kN.m	1500
	Max. lifting height of the boom (fully extended)	m	49
	Max. lifting height of the jib	m	65.7
Dimensions	Overall dimensions (L × W × H)	mm	14930×3400×3960
	Outrigger spread (longitudinal × transversal)	mm	8000×8000
	Boom length	mm	12300-48000
	Jib length	mm	9500, 16000
	Boom angle	°	-1-80
	Slewing range		360° continuous
Working speeds	Max. hoist rope speed (Main winch)	m/min	145
	Min. boom telescoping-out time	s	110
	Min. boom telescoping-in time	s	120
	Min. boom derricking-up time	s	55
	Min. boom derricking-down time	s	100
	Slewing speed	r/min	0-2
Hydraulic system	Rated working pressure	MPa	28
	Rated working flow	L/min	320
	Hydraulic oil tank capacity	L	1000
Weight and load	Gross weight	kg	51000
	Front axle load	kg	25200
	Rear axle load	kg	25800
Driving	Max. driving speed	km/h	37/25 (ZF) 37/37 (DANA)
	Wheelbase	mm	4250
	Treads(Front / Rear)	mm	2632
	Max. gradeability	%	ZF+Hande: 65% Other combination: 75%

Type	Item	Unit	Main configuration
Power system	Engine manufacturer & model		Cummins QSB6.7
	Fuel type		Diesel
	Intake system		Turbo-charged, air-to-air intercooling
	Cooling system		Water-cooling
	Engine rated power	KW/rpm	194KW/2200rpm (Dongfeng Cummins) 194KW/2400rpm (US Cummins)
	Engine rated torque	N.m/rpm	990N.m/1500rpm
	Fuel tank capacity		300 L
Drive system	Transmission drive mode		4×2, 4×4
	Transmission brand or model		ZF DANA
	Transmission gear		6 forward and 3 reverse gears (ZF) 6 forward and 6 reverse gears (DANA)
Travelling system	Suspension		Rigid (front) / Flexible (rear)
	Axle brand or model		Hande/Meritor
	Steering mode		Front-wheel steering Rear-wheel steering 4-wheel steering Crab steering
	Tire size		29.5-25-34PR
	Tire number		4
Hydraulic system	Main valve brand		Zoomlion
	Pump		Hengli/Liyuan/WANY
	Balance valve / hydraulic lock		NEM/Zoomlion/Dingsheng
Electrical system	Load moment limiter		Zoomlion/HIRSCHMANN
Emission			T III

Configuration



Superstructure

<p>Main boom</p>	<p>The box-shaped telescopic boom consists of 5 U-type boom sections made of high-strength steel. The telescopic boom sections are telescoped in / out via two telescopic cylinders and two sets of boom extension/retraction ropes. Each telescopic cylinder is equipped with a plug-in balance valve.</p> <p>The boom head is equipped with 6 pulleys, which is convenient for changing wire rope reevings without removing the wedges. A rooster sheave is optional.</p> <p>Main boom length (fully retracted): 12300mm</p> <p>Main boom length (fully extended): 48000mm</p> <p>Telescoping-out time: 110s</p>
<p>Jib</p>	<p>It consists of two lattice jib sections. The jib section II can be stretched out from the inside of the jib section I, and the whole jib is fixed at one side of the main boom during transport. A single pulley is assembled at the jib head.</p> <p>Jib angle: 0°, 15° and 30°</p> <p>Jib length: 9.5m~16m</p>
<p>Derricking mechanism</p>	<p>A front-mounted single derricking cylinder is installed with a derricking balance valve.</p> <p>Derricking angle: -1°~80°</p> <p>Derricking speed: -1°~80°/ 55s</p>
<p>Hoisting mechanism</p>	<p>Main and auxiliary winchs</p> <p>Main and auxiliary winches share the same fittings. Load hoisting and lowering are realized through the rotation of the drum driven by the planetary reducer, which is driven by the variable axial piston hydraulic motor.</p> <hr/> <p>Wire rope</p> <p>High strength wire rope (anti-twisting rope is optional)</p> <p>Max. hoist rope tensile force: 6500kg</p> <p>Max. hoist rope speed: 145m/min (At the 4th layer)</p> <p>Rope diameter: Φ20mm</p> <p>Main winch rope length: 260m</p> <p>Auxiliary winch rope length: 140m</p>
<p>Hoisting mechanism</p>	<p>Hook</p> <p>Main hook for 70t: with 6 pulleys and a hook latch, secured at the front of the chassis frame.</p> <p>Auxiliary hook for 6.5t: with a hook latch, used with the rooster sheave and jib, secured at the auxiliary hook holder on the chassis frame.</p>

	Hook for 90t (optional): with 6 pulleys and a hook latch, secured at the front of the chassis frame.
Slewing mechanism	<p>It consists of such parts as hydraulic motor, planetary gear reducer, pinion gear and slewing ring, etc. Via the planetary gear reducer, the hydraulic motor drives the pinion gear to rotate and makes the slewing bearing's outer ring rotate around its inner toothed ring fixed on chassis frame, realizing 360° unlimited slewing of the superstructure.</p> <p>Hydraulically controlled normally-closed brake with controllable slewing function and 360° hydraulic slewing lock.</p> <p>Slewing speed: 0~2 r/min</p>
Slewing platform	Wall plate structure
Counterweight	Fixed counterweight of 8.8t
Hydraulic system	<p>Oil pump</p> <p>Two variable pumps supply hydraulic oil to the telescoping, derricking and hoisting mechanisms and provide pilot oil.</p> <p>One gear pump supplies hydraulic oil to braking system, oil radiator of chassis torque converter, and superstructure AC.</p> <p>The other gear pump supplies hydraulic oil to outriggers, slewing mechanism and steering system.</p>
	<p>Control valve</p> <p>Quadruple downstream-pressure compensation hydraulic-controlled multiplex directional valve.</p>
	<p>Pipeline</p> <p>Hydraulic oil return lines are fitted with an air-cooled hydraulic oil cooler driven by an electric motor.</p> <p>The system pressure can be displayed on the instrument console. Hydraulic pipelines are fitted with pressure test ports.</p>
	<p>Hydraulic oil tank</p> <p>Capacity: 1000L</p> <p>The built-in return oil filter has a defoaming function. The filter fineness is 10μm.</p>
Crane control	<p>Operations of the superstructure are controlled by the two hydraulic joysticks on both sides of operator's seat.</p> <p>The left joystick controls the slewing mechanism and the auxiliary winch;</p> <p>The right joystick controls the derricking mechanism and the main winch.</p> <p>Hoisting, derricking and telescoping can be executed synchronously.</p>
Cab	For ZRT900, both crane operation and driving are performed in the driver's cab. It is a

	<p>side-mounted one-seat left-hand driving cab.</p> <p>Both sides of the seat are equipped with an armrest box. The left armrest box can be pulled up.</p> <p>Cab dimensions:</p> <p>Length: 1810±5mm</p> <p>Width: 1050±5mm</p> <p>Height: 1710±5mm</p>
<p>Load moment limiter</p>	<p>If the actual load moment approaches the rated one, the buzzer sends out a sound-light alarm and all dangerous operations of the crane are cut off automatically if the rated load moment is reached.</p> <p>The load moment limiter can also limit working ranges, such as working radius, boom angle, lifting height, slewing range, etc.</p> <p>The following information can be displayed on the monitor:</p> <ul style="list-style-type: none"> - Boom angle or moment ratio; - Boom length or default hook weight; - Actual working radius or slewing angle; - Actual lifting capacity; - Max. permissible lifting capacity; - Jib angle or wire rope reeving; - Indication of boom position; - Outrigger position or “On Tires” indication. <p>The following information is displayed by bar graph:</p> <ul style="list-style-type: none"> - Dynamic moment percentage; - Working pressure of hydraulic system.
<p>Outriggers</p>	<p>H-type outriggers, hydraulically controlled, can be operated in the cab simultaneously or independently.</p> <p>Each vertical jack cylinder is equipped with a two-way hydraulic lock to ensure the secure lock of outriggers during working or driving.</p> <p>Outrigger boxes are directly welded on the chassis frame.</p> <p>The outriggers can be completely extended, half extended or completely retracted for different operating modes.</p> <p>Outrigger spread (longitudinal): 8000mm</p> <p>Outrigger spread (transversal): 8000mm (fully extended) 5600mm (half extended) 3150mm (fully retracted)</p>

Transport



Transport of the main body (meeting road transport requirements)

Dimensions: width of 3.4m, height of 3.96m;

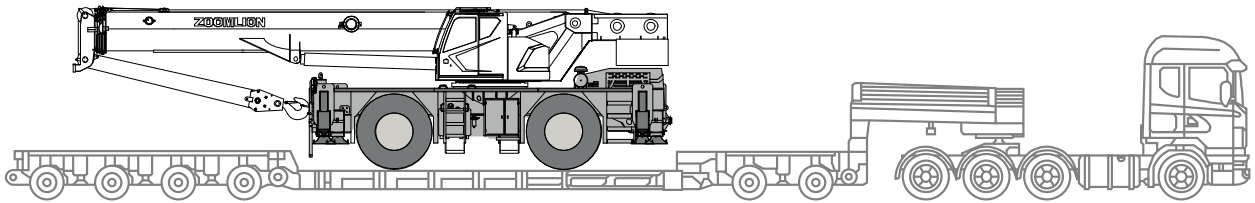

Weight: 51t (with counterweight, jib and hook)



Axle load distribution





		
51000kg	25200kg	25800kg

Combination of Jib Sections





Jib - 9.5m	
Jib - 16m	

Component	Structural form	Dimensions (L×W×H)	Weight
Jib section 1 + jib section 2 + connecting bracket		Foldable 10000mm×1200mm×850mm	810kg

Hook

				Standard ● Optional ○
70t	589	1600×600×560	12	●
6.5t	150	900×300×300	1	●
90t	780	1650×750×550	12	○

Wire rope

			
	20mm	260	6.5 t
	20mm	140	6.5 t

Operating Modes

T Main boom

F Jib

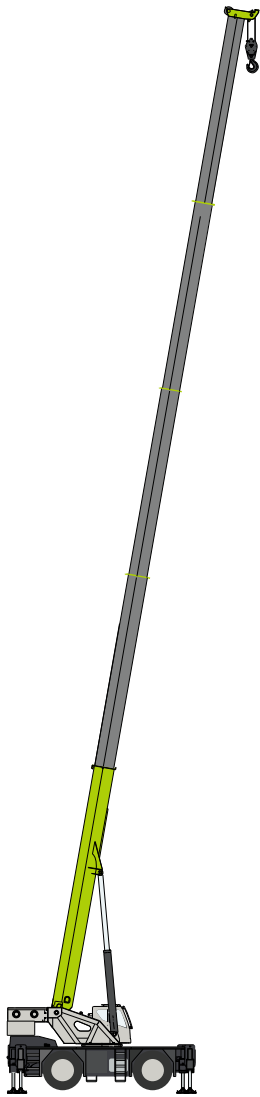

T5

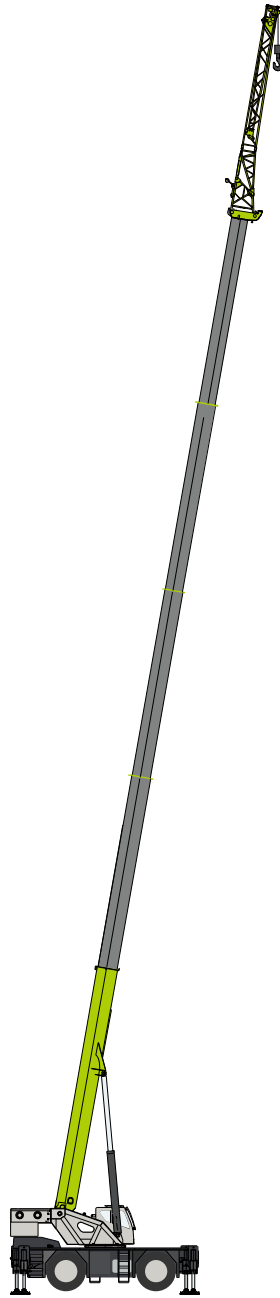

T5+F1

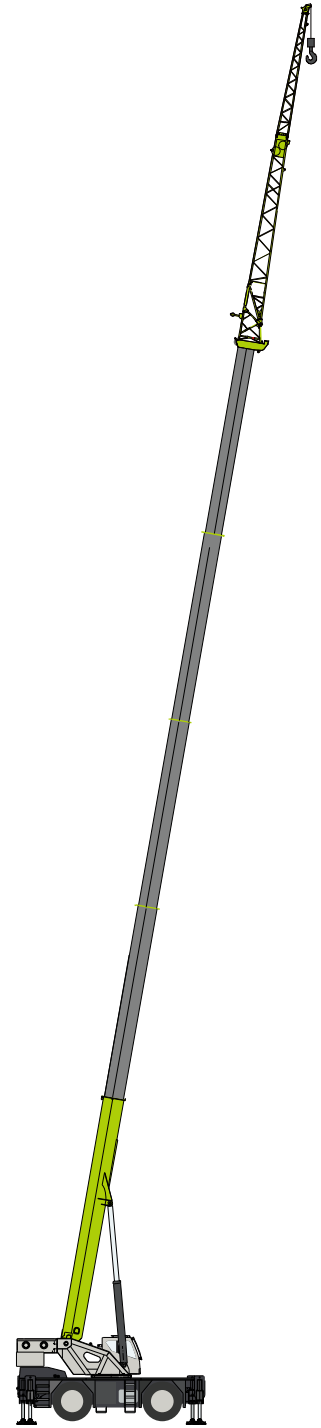

T5+F2

Lifting Height Curve + Lifting Capacity Chart

Rated lifting capacity charts are provided for different operating modes of the crane. The operator should choose the correct capacity chart and determine the rated lifting capacity according to the actual operating mode.





Values in Column "I" represent the extended length of the telescopic cylinder I under a corresponding OM. The values in Column "II" represent three times the extended length of the telescopic cylinder II under a corresponding OM.





Matters needing attention:

- a) The hook for 90T should be used if the rated lifting capacity exceeds 70t. For operating modes marked with "*" in the table, the crane should be retrofitted with special devices.
- b) Rated load of the crane is provided based on the fact that the crane stands on a leveled, solid and flat supporting ground.
- c) Rated load of the outriggers is provided based on the fact that the outriggers are fully or half extended or fully retracted and the tires are supported off the ground. Rated load must not be exceeded and do not load the crane with heavy objects to determine its allowable loads.
- d) The load must be lifted vertically. Do not pull the load with an angle.
- e) When the working radius and the main boom length are within the range of the listed values in the table, the smaller value of rated load should be adopted.
- f) The boom angle shown on the lifting height chart is an approximate value for the working radius of a certain boom length. The boom angle should be larger before loading to account for boom deflection.
- g) Rated load includes the weight of hook, wire rope, and auxiliary lifting devices. The net load is obtained by subtracting the weight of these devices from the rated load.
- h) Rated load of the tires depends on tire pressure and tire condition. Be careful when increasing tire pressure. Please refer to the *Operator's Manual* for matters needing attention.
- i) For pick-and-carry operations in tires, the boom must be centered at the front of the crane with the slewing brake lock engaged. Keep the minimum lifting height of the boom so that the load approaches the ground. The crane must travel on a smooth and flat surface.
- j) Avoid swinging during load lifting.
- k) Creeping means the crane travels less than 61m (200ft) within 30minutes. The maximum creeping speed shall not exceed 1.44km/h (0.9mph).
- l) Please refer to the Operator's Manual for more details on pulley reeving and installation of wire rope.
- m) If a rope reeving larger than the specified reeving is adopted, the hook may not be able to touch the ground due to insufficient length of rope. Choose correct rope reeving according to Load Ratings.
- n) Proper maintenance of wire rope is an inseparable part of safe crane operation. Please refer to the *Operator's Manual* and *Maintenance Manual* for proper maintenance and inspection requirements.

- o) Rated load should be reduced according to adverse working conditions, such as soft or uneven ground, unbalanced surface, strong wind, lateral load, swing operation, on-load yanking or sudden stop, dangerous state, inexperienced personnel, lifting with two cranes, traveling with load, electric wires, etc. (Lateral push and pull of the main boom or the jib is dangerous). Stop working immediately and retract the boom to the state for driving if the wind speed is higher than 14.1m/s (46.2ft/s) or there is lightning when the crane is working.
- p) Maintenance of the crane should be carried out in line with the *Operator's Manual* and *Maintenance Manual* so as not affect its load ratings.

Symbolic signs

Sign	Description
	Main boom
	Boom length (m)
	Jib
	Slewing of 360°
	Rope reeving

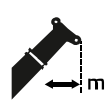
Sign	Description
	Outriggers fully extended
	Outriggers half extended
	Outriggers fully retracted
	8.8t counterweight
	Working radius (m)

Lifting Height Curves

Lifting height curves with outriggers fully extended

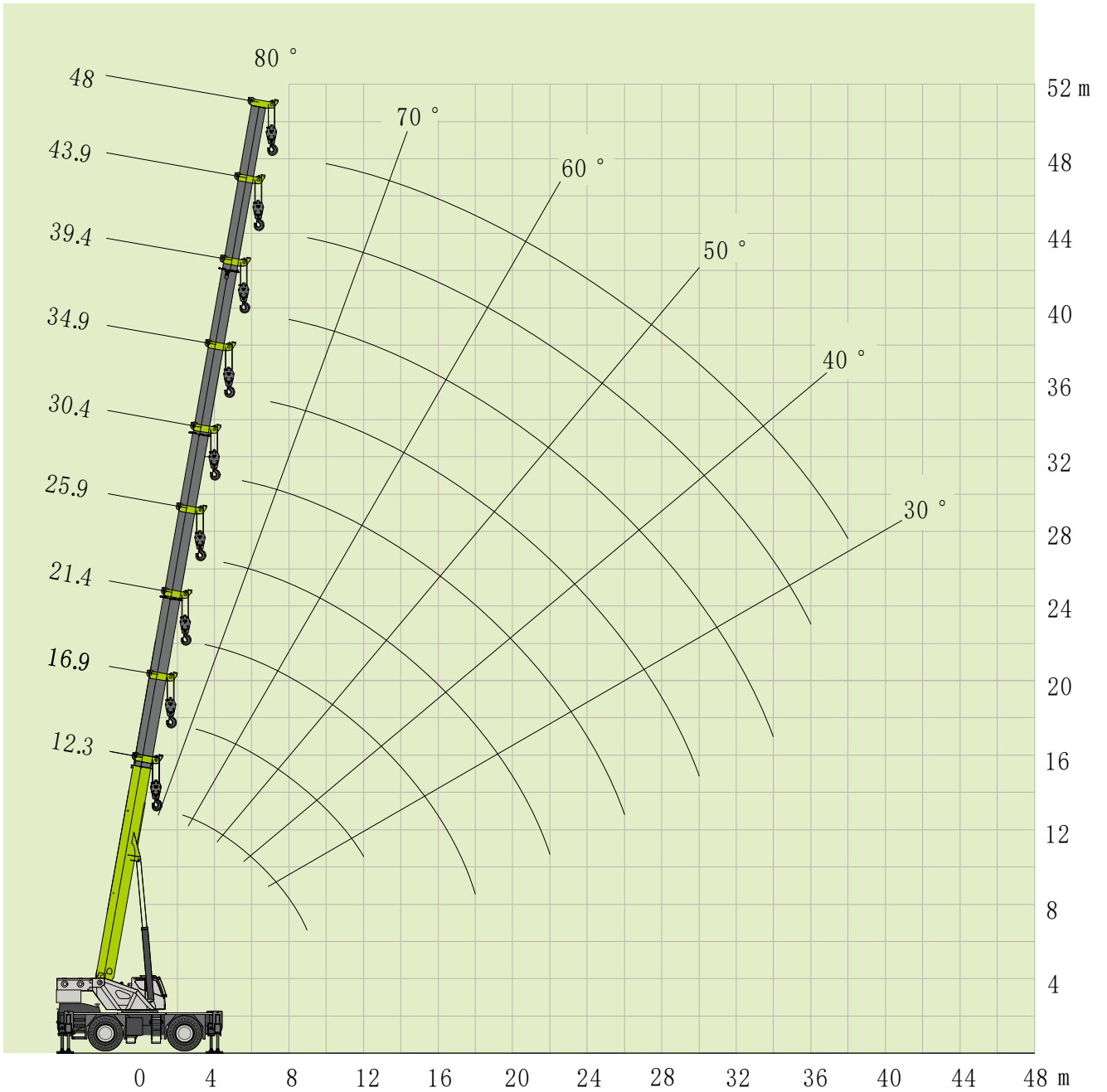









Table 1 Rated lifting capacity chart of main boom with outriggers fully extended

										Unit: t
	12.3	16.9	21.4	25.9	30.4	34.9	39.4	43.9	48	
2.5	90*									
3.0	85*	58								
3.5	75	58	45							
4.0	68	55	45							
4.5	63	54	45	31						
5.0	58	52.5	43.2	31						
5.5	53	50.5	41.2	31	28.5					
6.0	50.2	47.5	39.2	31	28.5					
7.0	42	39.5	35.2	30	28	24.5				
8.0	35.5	33.5	31.2	27.5	26	22	19.5			
9.0	27.5	27.2	26.5	25.5	23.5	21	18.3	15.8		
10.0		21.6	21.5	21.5	21.5	19	17	15	11.8	
11.0		17.8	17.5	17.8	18	17.5	15.8	14	11.6	
12.0		15	14.5	14.8	15.5	16.5	14.6	13	11.6	
14.0			10.5	10.8	12	12	12.6	11.5	10.3	
16.0			7.7	8.2	9.2	9.6	9.8	10	9.4	
18.0			5.5	6.2	7.2	7.7	8	8.1	8.5	
20.0				4.8	5.7	6.1	6.4	6.6	7	
22.0				3.7	4.5	4.8	5.3	5.5	5.7	
24.0					3.5	3.9	4.3	4.5	4.6	
26.0					2.7	3.1	3.5	3.7	3.8	
28.0						2.4	2.8	3	3.2	
30.0						1.8	2.3	2.5	2.7	
32.0							1.8	2	2.2	
34.0							1.3	1.5	1.7	
36.0								1.1	1.3	
38.0									1	
I	0	4.6	9.1	9.1	9.1	9.1	9.1	9.1	9.1	
II	0	0	0	4.5	9.0	13.5	18.0	22.5	26.6	
	12	10	8	6	6	5	4	3	3	
	70t									

Lifting Height Curves

Lifting height curves with outriggers fully extended + jib installed

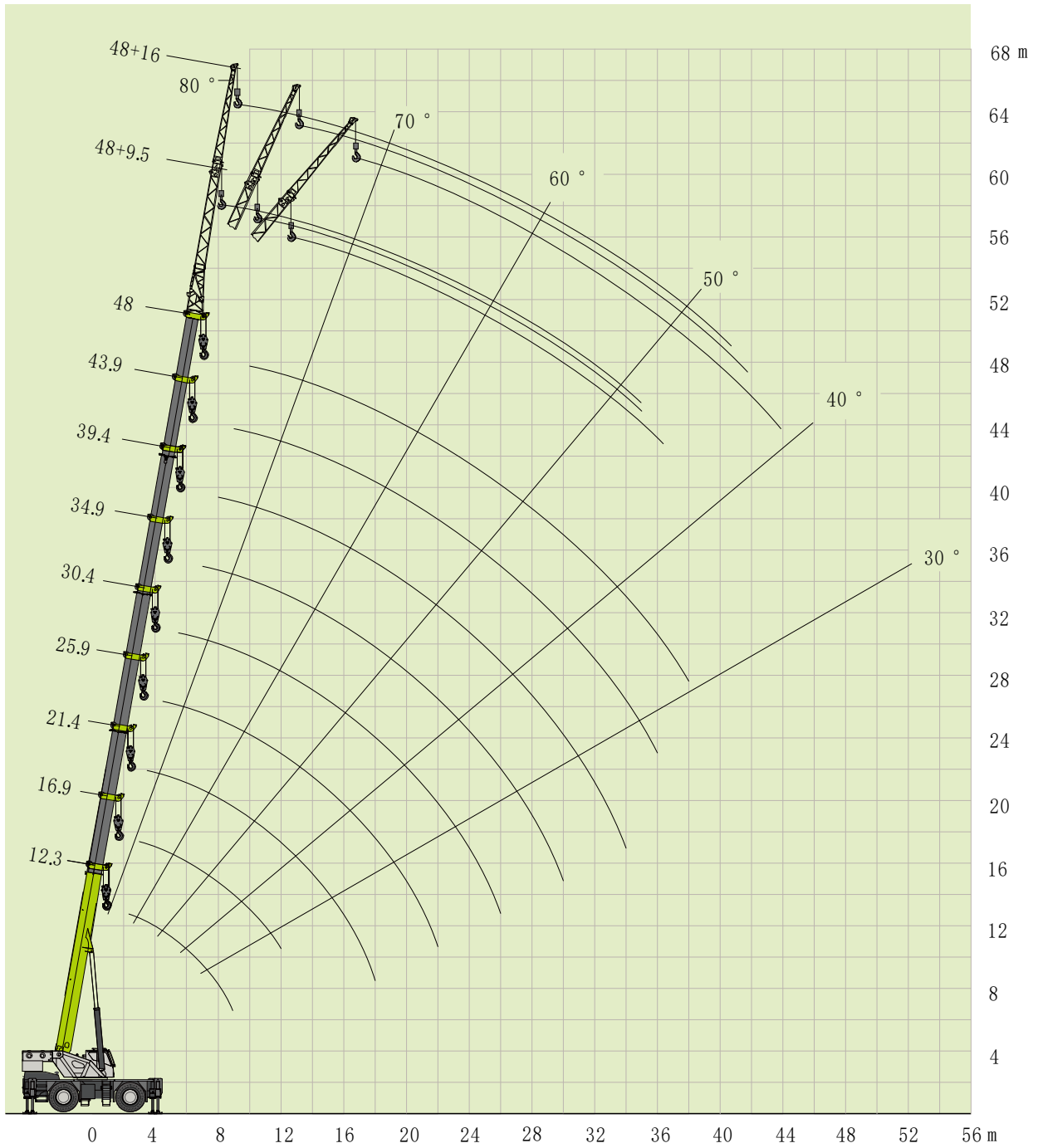





Table 2 Rated lifting capacity chart of main boom + jib with outriggers fully extended

 Unit: t						
Main boom angle (°)	48+9.5			48+16.0		
	0°	15°	30°	0°	15°	30°
80	5	3.3	2.5	3	2	1.5
78	5	3.3	2.5	3	2	1.45
76	4.8	3.2	2.5	2.8	1.9	1.4
74	4.5	3.1	2.5	2.6	1.8	1.35
72	4.2	3	2.5	2.4	1.7	1.3
70	3.9	2.9	2.4	2.2	1.65	1.25
68	3.6	2.8	2.3	2.1	1.6	1.25
66	3.4	2.6	2.2	2	1.55	1.2
64	3.2	2.5	2	1.9	1.5	1.2
62	2.9	2.4	1.95	1.8	1.45	1.15
60	2.5	2.1	1.9	1.7	1.4	1.1
58	2.2	1.8	1.7	1.5	1.35	1.05
56	1.9	1.5	1.5	1.3	1.2	1
54	1.6	1.3	1.2	1.2	1.1	0.95
52	1.4	1.1	1	1	0.9	
50	1.2	0.9		0.8		
48	0.9					
	1					
	6.5t					

ZOOMLION



Zoomlion Heavy Industry Science & Technology Co.,Ltd.

 www.zoomlion.com

 Sos-service@zoomlion.com

 Quantang Industrial Park, No. 1636, 2nd Yuanda Road, Changsha, Hunan Province, China

